

Werkzeughalter | Toolholder

HSK25-E

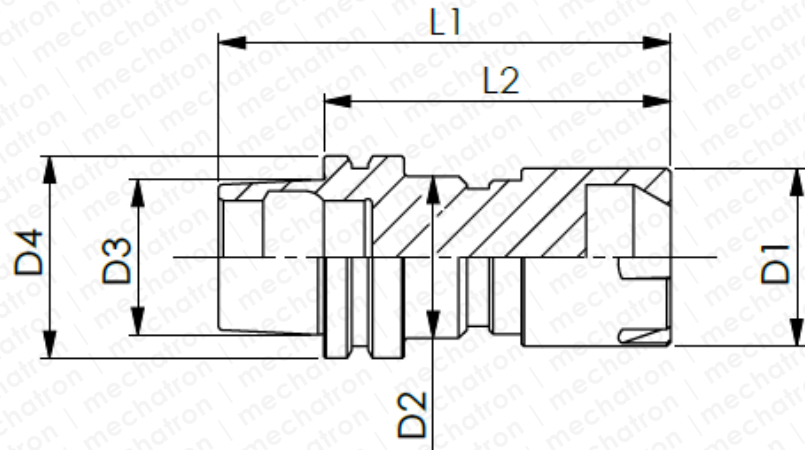

mechatron



Art. Nr. Art. No.	Ausführung Type	Maße* Dimensions*						Spannbereich* Claming Range*
		D1	D2	D3	D4	L1	L2	
3309	ER16	22	20	19,19	25	56	43	1-10
6258	ER20	28	24	19,19	25	61	48	1-13
5791	ER25	35	30	19,19	25	83	70	1-17

*in mm