

# Werkzeughalter | Toolholder

## NBT30

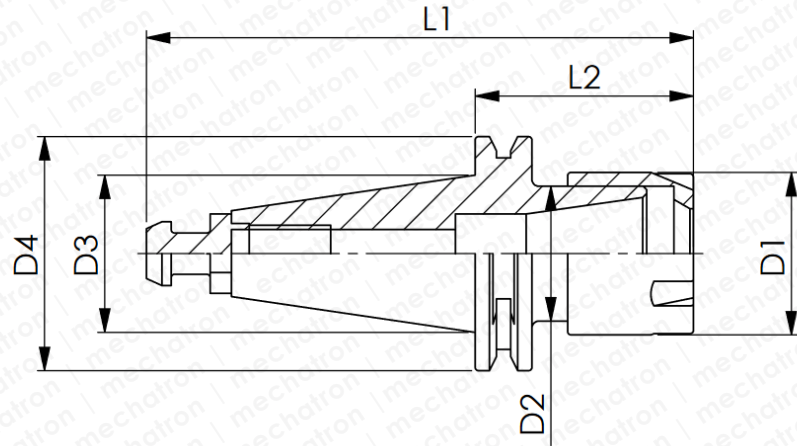

mechatron



Art. Nr. Art. No.	Ausführung Type	Maße*   Dimensions*						Spannbereich* Claming Range*
		D1	D2	D3	D4	L1	L2	
4317	ER11	19	19	31,75	46	132,4	60	1-7
4318	ER11	19	19	31,75	46	172,4	100	1-7
4313	ER16	28	28	31,75	46	134,9	60	1-10
4221	ER20	33,6	25	31,75	46	127,3	60	1-13
4314	ER20	33,6	25	31,75	46	137,3	70	1-13
4319	ER20	33,6	25	31,75	46	167,3	100	1-13
4344	ER25	42	34	31,75	46	125,4	60	1-17
4315	ER25	42	34	31,75	46	135,4	70	1-17
4316	ER32	50	40	31,75	46	137,7	70	1-20

\*in mm

Anzugsbolzen M12 inklusive  
Pull stud M12 included