

# Werkzeughalter | Toolholder

## ISO 20

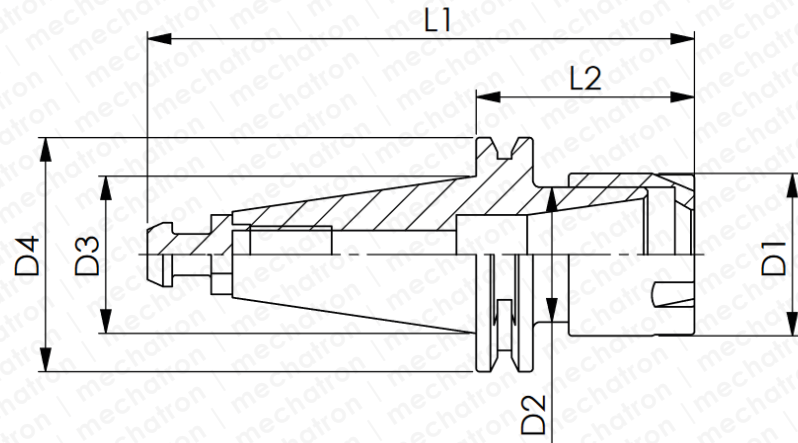

mechatron



Ausführung Type	Maße*   Dimensions*						Spannbereich* Claming Range*
	D1	D2	D3	D4	L1	L2	
<b>ER16</b>	22	22	22,23	30	97,5	50	1-10
<b>ER20</b>	28	28	22,23	30	102,7	55	1-13
<b>ER25</b>	42	34	22,23	30	105,4	58	1-17

\*in mm

Anzugsbolzen M8 nicht inklusive