

Werkzeughalter | Toolholder

NBT30

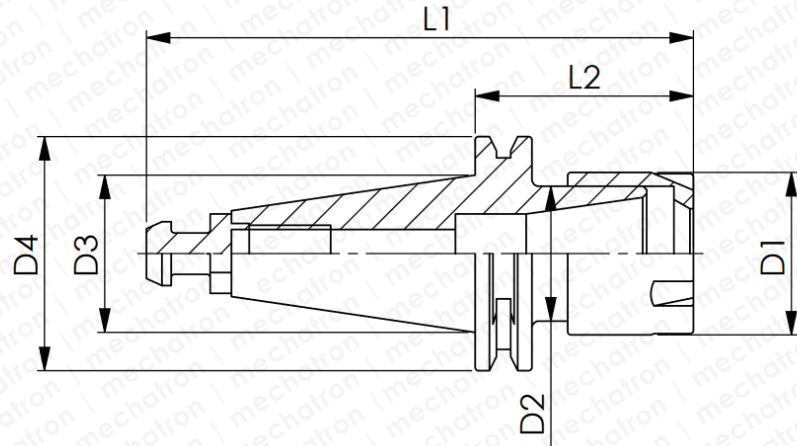

mechatron



Ausführung Type	Maße* Dimensions*						Spannbereich* Claming Range*
	D1	D2	D3	D4	L1	L2	
ER11	19	19	31,75	46	132,4	60	1-7
ER11	19	19	31,75	46	172,4	100	1-7
ER16	28	28	31,75	46	134,9	60	1-10
ER20	33,6	25	31,75	46	127,3	60	1-13
ER20	33,6	25	31,75	46	137,3	70	1-13
ER20	33,6	25	31,75	46	167,3	100	1-13
ER25	42	34	31,75	46	125,4	60	1-17
ER25	42	34	31,75	46	135,4	70	1-17
ER32	50	40	31,75	46	137,7	70	1-20

*in mm

Anzugsbolzen M12 inklusive